

# Model 187Ka 150W TWT Amplifier

**25%  
DUTY**



## FEATURES:

- Frequency 34-36 GHz
- Low Spurious Outputs
- Phase and Amplitude Stability
- Complete TWT Protection
  - Pulse Input Protection
  - Helix Overcurrent
  - Cathode Over/Undervoltage
  - Filament Low Voltage
  - Overtemperature
  - Input Energy Limit
  - Reverse Power Monitor
- Custom Requirements
- Solid State Except for the TWT
- Front Panel Voltage Adjustments
- Front Panel Fault Isolation
- Modular Construction
- DC TWT Filaments
- Four Line Display
  - Operating Mode
  - Cathode Voltage
  - Helix Current
  - Filament and Operate Time
- Front Panel Controls
  - Power On / Off
  - Operate
  - Standby
  - Fault Reset
  - Local / Remote

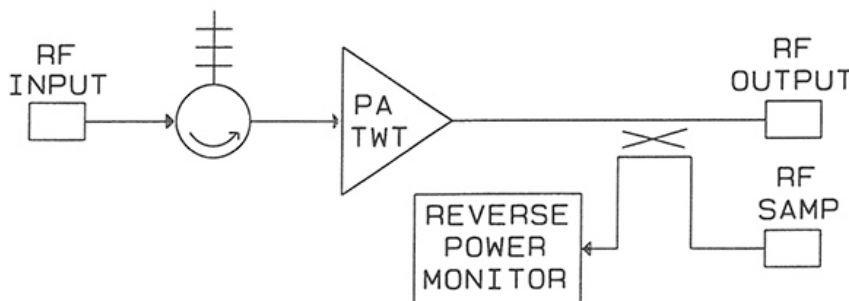

The Model 187Ka TWT Amplifier has been designed specifically to operate pulsed traveling wave tubes up to 200 watts peak power at frequencies in the 35 GHz range. Particular emphasis has been placed on the generation of the output RF pulse shape without the use of RF switches. Pulse width control is with an external pulse.

The High Voltage Power Supplies are modular DC-DC converter designs. The Power supply design provides superior stability for optimum TWT phase noise and spurious performance.

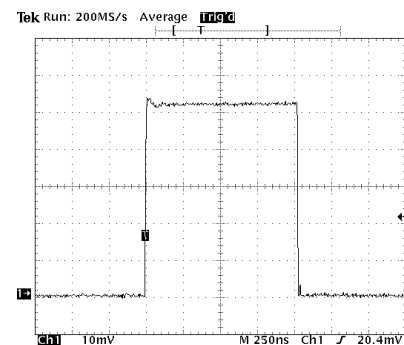

Detected RF Output

## Model 187 150W TWT Amplifier SPECIFICATIONS

Duty Cycle	25%, Nominal
Pulse Width Range	0.05 to 100.0 $\mu$ s
PRF Range	0 to 100 kHz
RF Rise / Fall Time	15 ns, Maximum
RF Pulse Droop	< 0.1 dB, Maximum
Delay, Input to RF	200 ns, Maximum
Phase Noise	< $\pm 1^\circ$ pk to pk
Amplitude Variation	0.1 dB, Maximum
Spurious Outputs	-40 dBc, Maximum
Input Pulse	5 Volts into 50 ohms
Noise Figure	35 dB, Nominal
RF Connectors	Waveguide
Primary Power	120/220/240 VAC $\pm 10\%$ , 50/60 Hz
Operating Temperature	-20 $^\circ$ to +50 $^\circ$ C
Weight	100 lbs, Nominal
Dimensions	8.75x19x28.5(in.)

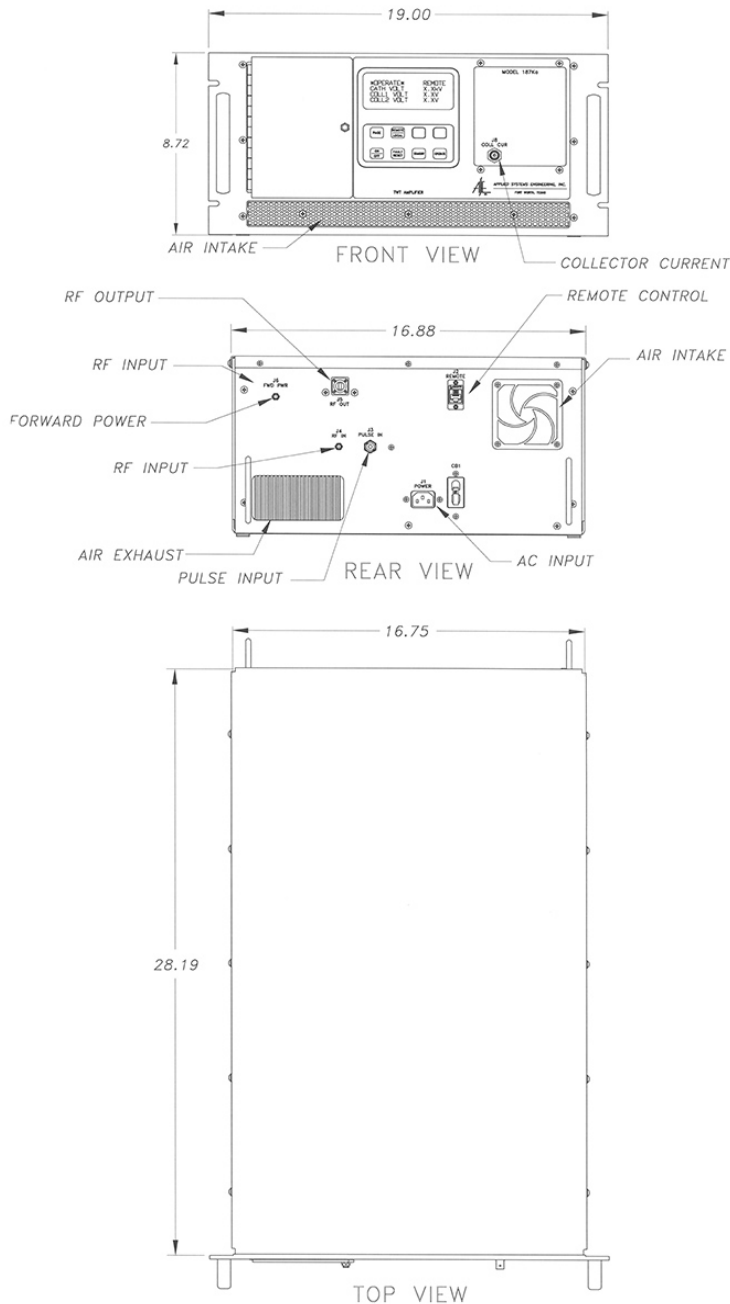

## Standard Equipment

- Filament / Operate Time
- Remote Power On/Off
- Ethernet Remote Control (TCP/IP or UDP/IP)
- RF Input Isolator
- Reverse Power Monitor
- Forward RF Sample Port

## Options

- Driver Amplifier
- Other PRF and Pulse Width Ranges
- Extended Frequency Coverage
- Higher Peak Power
- Reverse RF Sample Port
- RS-232/422 or IEEE-488 Remote Control
- Other Primary Power
- Outdoor Enclosure
- RF Connectors on Front Panel
- Harmonic Filters
- RF Input Attenuator
- Reverse Power Fold Back Protection
- Conformal Coated PC Boards