

Model 176 1kW TWT Amplifier

6.0%
DUTY



FEATURES:

- Frequencies from 1 to 18 GHz
Octave and Multi-Octaves Available
- Low Spurious Outputs
- Phase and Amplitude Stability
- Complete TWT Protection
 - Pulse Input Protection
 - Helix Overcurrent
 - Cathode Over/Undervoltage
 - Collector Overvoltage
 - Filament Low Voltage
 - Overtemperature
 - Input Energy Limit
 - Reverse Power Monitor
- Custom Requirements
- Solid State Except for the TWT
- Front Panel Voltage Adjustments
- Front Panel Fault Isolation
- Modular Construction
- DC TWT Filaments
- Four Line Display
 - Operating Mode
 - Cathode Voltage
 - Collector Voltage
 - Helix Current
 - Filament and Operate Time
- Front Panel Controls
 - Power On / Off
 - Operate
 - Standby
 - Fault Reset
 - Local / Remote

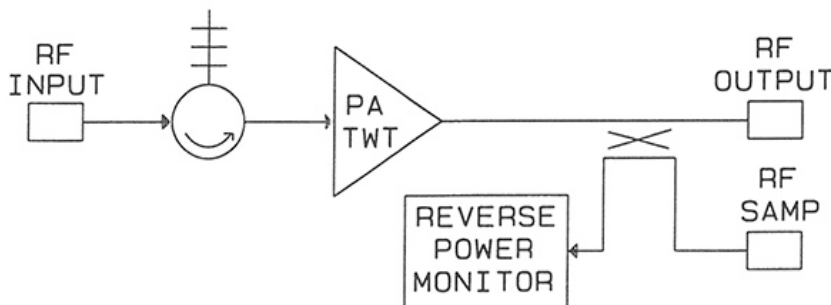

The Model 176 TWT Amplifier has been designed specifically to operate pulsed traveling wave tubes in the 1 to 2 kW peak power range at frequencies up to 18 GHz. Particular emphasis has been placed on the generation of the output RF pulse shape without the use of RF switches. Pulse width control is with an external pulse.

The High Voltage Power Supplies are modular DC-DC converter designs. The Power supply design provides superior stability for optimum TWT phase noise and spurious performance.

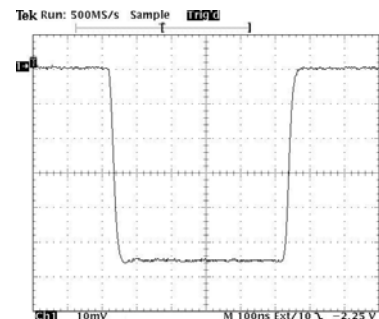

Detected RF Output

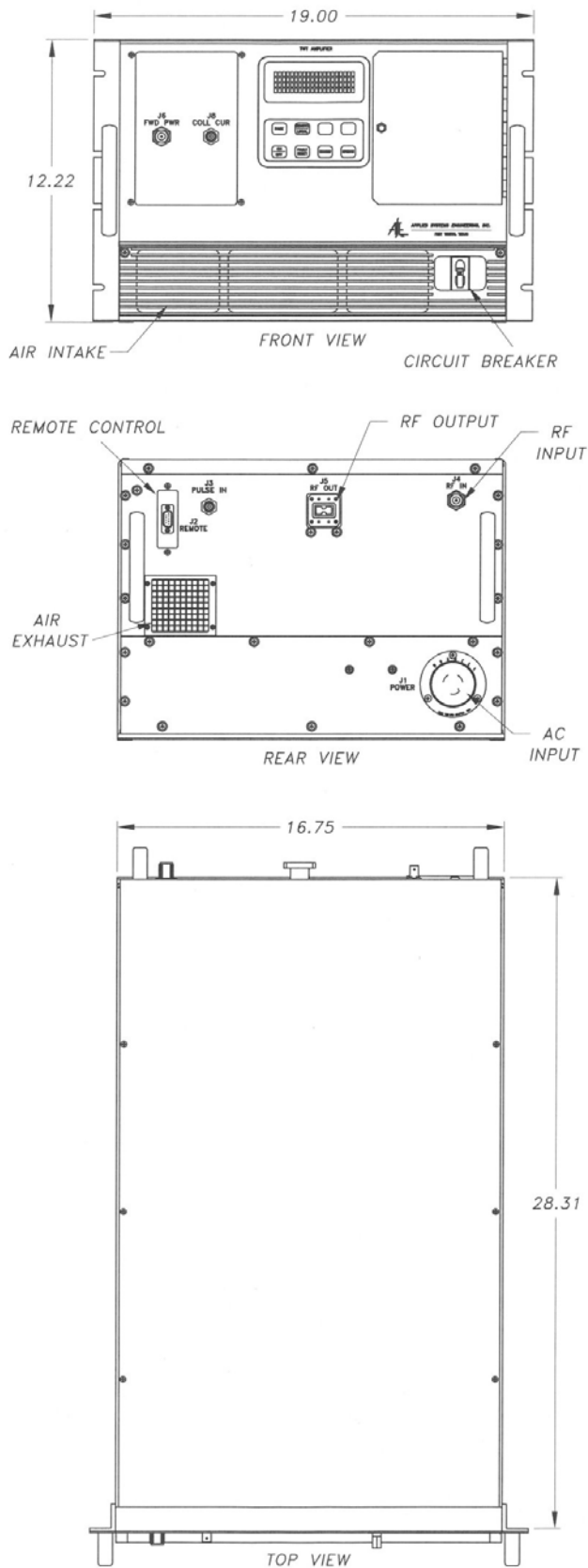

Model 176 TWT Amplifier SPECIFICATIONS

Duty Cycle	6.0%, Maximum
Pulse Width Range	0.07 to 100 us
PRF Range	0 to 400 kHz
RF Rise / Fall Time	15 ns, Maximum
RF Pulse Droop	0.5 dB/100 us, Maximum
Delay, Input to RF	200 ns, Maximum
Phase Noise	< $\pm 1^\circ$ pk to pk
Amplitude Variation	0.1 dB, Maximum
Spurious Outputs	-50 dBc, Maximum
Input Pulse	5 Volts into 50 ohms
Noise Figure	35 dB, Nominal
RF Connectors	Precision Type N or Waveguide
Primary Power	120 VAC $\pm 10\%$, 50/60 Hz
Operating Temperature	-20° to +50°C
Weight	130 lbs, Nominal
Dimensions	12.25x19x28.5(in.)

Standard Equipment

- Filament / Operate Time
- Remote Power On/Off
- Ethernet Remote Control (TCP/IP or UDP/IP)
- RF Input Isolator
- Reverse Power Monitor
- Forward RF Sample Port

Options

- Driver Amplifier
- Pulse Width up to 125 μ sec
- Extended Frequency Coverage
- Higher Peak Power
- Reverse RF Sample Port
- Detected RF Output
- RS-232/422 or IEEE-488 Remote Control
- Other Primary Power
- Outdoor Enclosure
- RF Connectors on Front Panel
- Harmonic Filters
- Conformal Coated PC Boards



APPLIED SYSTEMS ENGINEERING, INC.

7510 BENBROOK PKWY, FORT WORTH, TEXAS 76126
TELEPHONE: (817) 249-4180 FAX: (817) 249-3413

mdl176_2e.wpd
07-14-22